

L33.2 / L33.2MC

Subminiature High-Efficiency All-In-One Triple LED Engine

- Triple CREE X-Light XP-G R5 at 1.1A (Pure White, 1100 Lumens)
- Input Voltage Range Optimized for Lithium 2S Batteries (4.8V to 9.5V)
- Boost High-Frequency Switching Regulator (1.6 MHz)
- Mode-Control Function, Remote Control ⁽¹⁾ (L33.2MC Version)
- Thermally-Enhanced Metal Core PCB Ø20mm
- Electrically Neutral Thermal Path
- Ultra-Low EMI Noise (Shielded Inductor, X7R 10µF Input Capacitor)
- Integrated Thermal Overheating Protection and Low-Power Cut-Off
- Shock and Vibration Tolerant Materials and Components

Note 1: The mode control function is described later in this document. In all other respects a single-mode version is equivalent to the L33.2MC

The L33.2 engine is a 1.1A constant current boost (step-up) regulator integrated with three CREE X-Light XP emitters designed to provide a simple, robust, cost-effective solution for light-demanding applications such as portable lighting, LED flashlights, interior and exterior illumination etc. The switching regulator is optimized for lithium cell voltage range (2S) and exhibits an exceptionally high efficiency (< 96%). This product is compatible with most wireless devices due to its low EMI noise level obtained by an optimal high-frequency board design and low-profile shielded inductor. The engine takes advantage of a thermally-enhanced metal core PCB (MCPCB) which provides very low thermal resistance and guarantees extremely high shock and vibration tolerance. The metal core is an electrically neutral which allows multiple engines to share the same heat sink with no need for insulation.



Absolute Maximum Ratings

Input Voltage Range	4.8V to 9.5V
Stabilized LED Current ⁽²⁾	1100mA
LED Luminous Flux ⁽²⁾	< 1100 Lumens
Thermal Cut-off Threshold	120 °C
Absolute Maximum Current Drain	2.74 A @ 4.75V
Absolute Maximum Consumed Power	12.9W @ 4.75V
Maximum Conversion Efficiency	96% @ 9.6V

Note 2: This is standard parameters provided by XP-G R5 LEDs installed by default. If you need a custom module please contact us before placing the order. The board admits any XP-series LEDs (white or colored) and hardware reduction of the current upper limit.

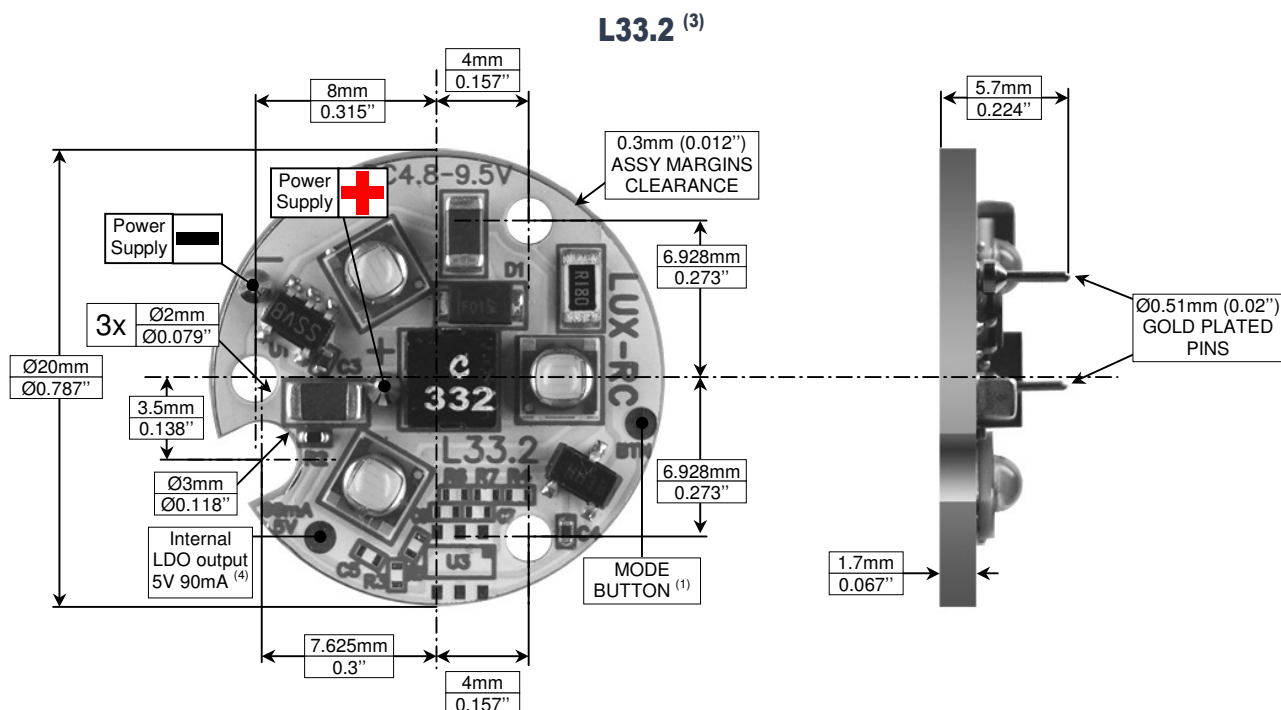

Note 3: The L33.2 should be installed on a flat clear heat sink. The engine can be either glued using a thermally conductive adhesive or fastened by a peripheral ring or nut. We recommend applying DOW CORNING 1-4173 thermally conductive adhesive or similar to minimize thermal resistance and attain maximum performance.

Note 4: The internally protected LDO output is set to 4V in older versions. Maximum load current should not exceed 90mA.

Electrical Characteristics

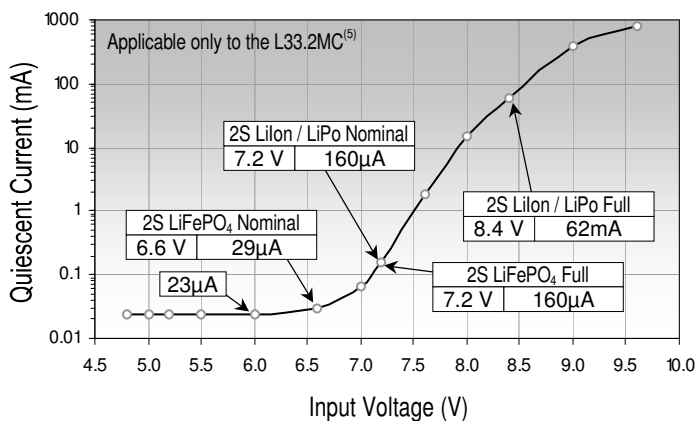
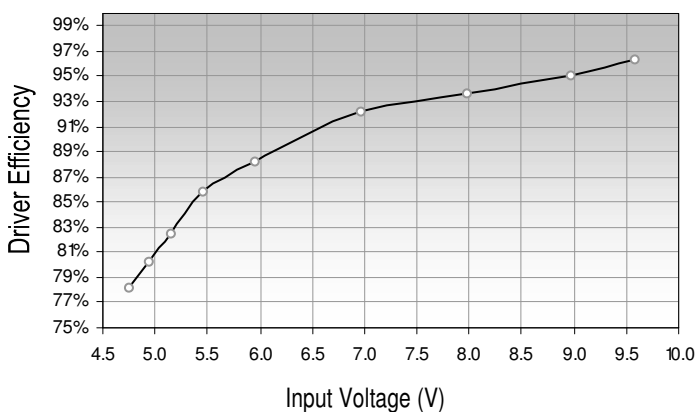
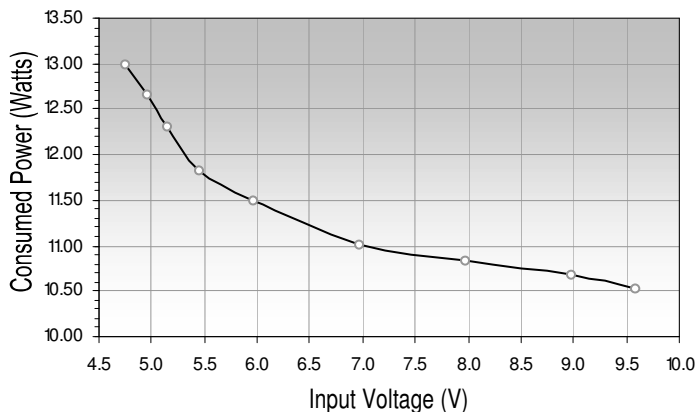
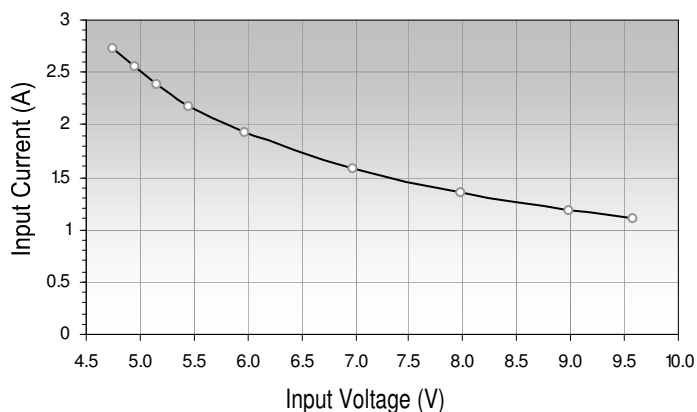

R_{SENSE} (0.18Ω) Voltage (100mV / DIV)⁽⁶⁾

LED + R_{SENSE} Voltage (5V / DIV)

LED Voltage AC Ripple (50mV / DIV)

LDO AC Ripple (50mV / DIV)

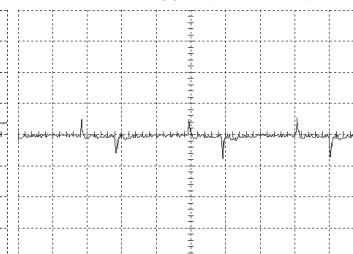
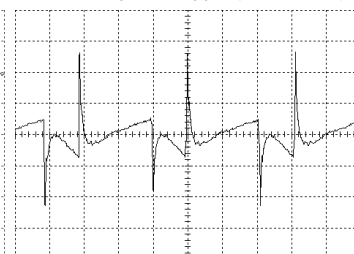
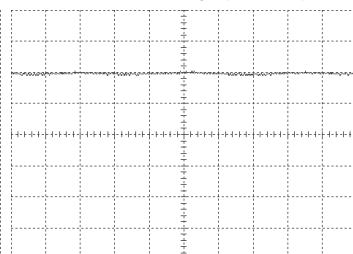
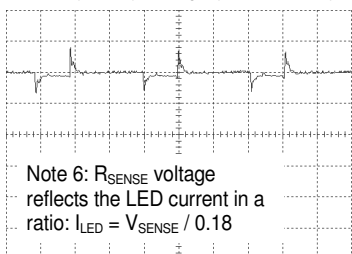

t (0.2μS / DIV)

t (0.2μS / DIV)

t (0.2μS / DIV)

t (0.2μS / DIV)

Duty Cycle @ 4.8V (5V / DIV)

Duty Cycle @ 7.2V (5V / DIV)

Duty Cycle @ 8.4V (5V / DIV)

Duty Cycle @ 9.6V (5V / DIV)

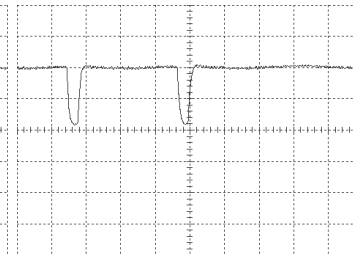
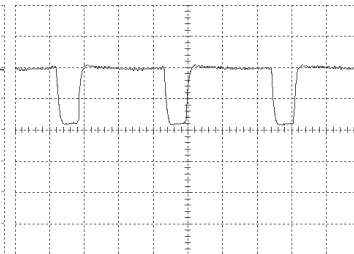
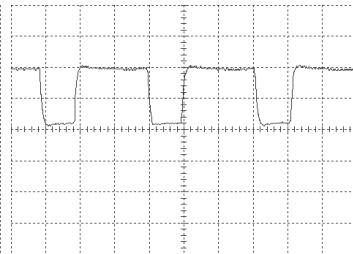
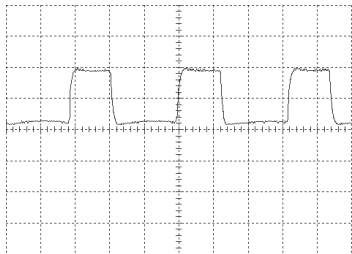

t (0.2μS / DIV)

t (0.2μS / DIV)

t (0.2μS / DIV)

t (0.2μS / DIV)

Note 5. The quiescent current is absolute minimum input current rating of L33.2MC board. Depending on the firmware version the actual stand-by current may vary. Not all firmware versions have a support for stand-by mode. Please contact us for more details.

L33.2MC - Mode Control Function

- Three preset output levels 100%, 20% and 2% toggled by power interrupt
- Smooth mode programming by an optional momentary button
- Smooth mode-switching for easy eyes accommodation
- Switching to full output and back to ECO in single click
- Collision prevention flashing signal
- Emergency SOS signal
- Two high-intense strobe patterns

The mode control function is implemented in L33.2MC board and provides simple yet flexible interface to manage the luminous output and signaling modes (strobe and emergency signals). The MC version features two different mode-control interfaces, which require minimum or even no external components or wiring.

A simple power-interrupt switch is used to toggle between 100%, 20% and 2% preset levels. The wiring diagram is shown on pic.2. The switch SW1 should be rated for maximum input current of L33.2 module. When disconnected from the battery, the module retains the last active mode in a transient memory during 5-7 seconds. A longer power outage interval fully resets the module and it starts again with initial 100% (full output) mode.

More options are available when an external momentary click-button is connected between the BTN and Ground (Negative) pins (pic.3). By a short single-click the module toggles between full output (100%) and adjustable ECO mode. The soft switching simulates halogen lamp inertia for easier eyes accommodation. By default the ECO is set at 20%. Holding the button in ECO mode for 2 seconds enables the ECO adjustment mode in which any level between zero and 50% can be programmed. Holding the button in full-output mode enables strobe and emergency signals selection menu.

We're constantly working on the firmware improvements, please visit Lux-RC Labs site (www.lux-rc.com) for latest updates. Your customization requests are also welcomed. We provide our customers with a complete design-implementation -quality control cycle at a very competitive price.

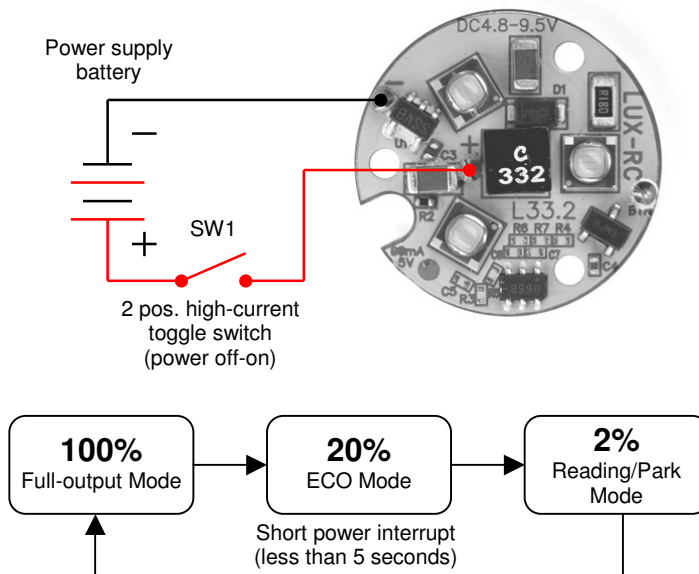

Pic.2. Switching modes using standard power off-on switch

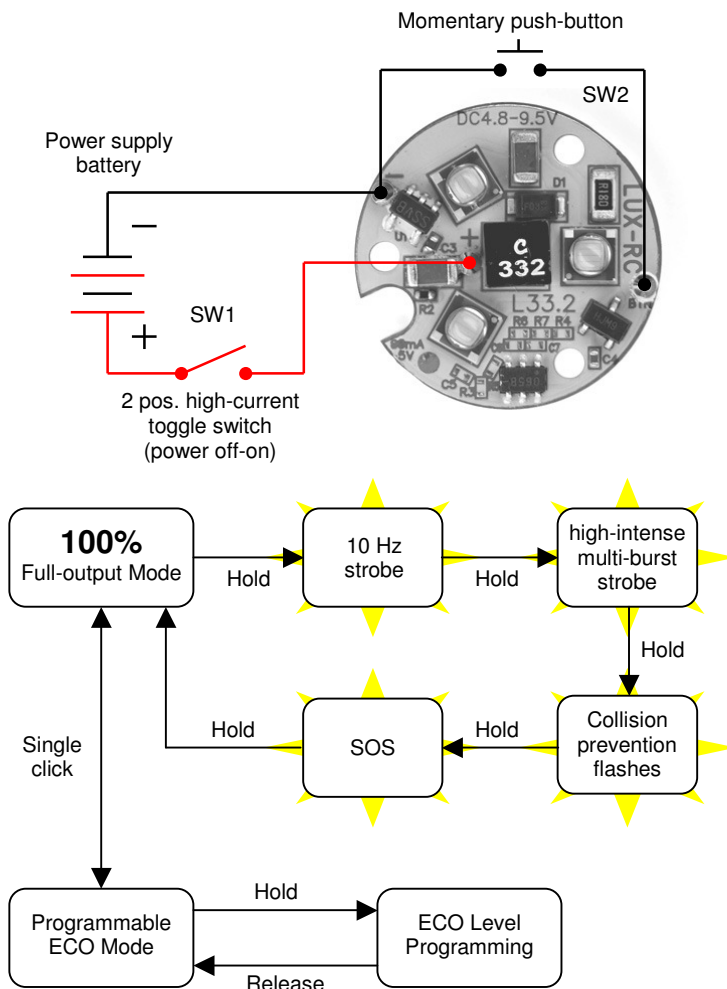

Pic.3. Programming using an optional momentary push-button